



LUBRICATION EQUIPMENT & ACCESSORIES



ABOUT SAMSON®



It starts with Samoa SA; world leader in vehicle lubrication equipment. Located in Gijon Spain, Samoa is the world leader in the design, manufacture and marketing of vehicle lubrication equipment. Marketing around the world through nine wholly-owned companies, Samoa is known worldwide for professional-grade quality products.

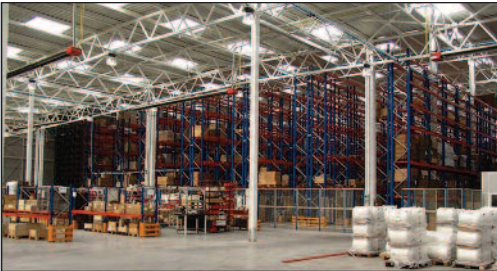

Occupied in December 2007, Samoa's Casares plant is a true world-class manufacturing facility.



This facility includes a highly-sophisticated coating process that insures the coatings are long-lasting, high-grade, durable products.



Fully automatic distribution center allows accurate and rapid order fulfillment around the world.



Throughout North America, Samoa's Products are Marketed by Samson Corporation, headquartered in Asheville North Carolina.

Lead by a team of industry professionals with decades of automotive equipment experience, Samson is leading the way in North America with quality products supported by a responsive customer-driven organization. Samson has developed an extensive network of service and installation support.



World Class Manufacturing  **Professional Grade Products**

STATIONARY GREASE PUMPS & PACKAGES

STATIONARY GREASE PUMP PACKAGES

Stationary Grease Pump Packages include a container cover, a follower plate, 5 foot air connecting hose, air line ball valve, air regulator and filter and 5 foot grease connecting hose.

KEG PACKAGES

Includes PM3 55:1 air pump, 5 ft. air inlet hose, air inlet ball valve, filter regulator with gauge and auto drain, 5 ft. grease connecting hose, follower plate, and container cover.

BK 817-1134* 120 lb. Keg package

BK 809-1023* 400 lb. Keg Package

* DRUM NOT INCLUDED



BK 809-1023

STATIONARY GREASE PUMPS

All Balkamp stationary grease pumps from Samson include a combination air regulator with gauge and an air filter with automatic drain.



120 LB. HEAVY-DUTY KEG PACKAGE

Includes PM3+3 55:1 pump, 5 ft. air inlet hose, air inlet ball valve, filter regulator with gauge and auto drain, 5 ft. grease connecting hose, follower plate, and container cover.

BK 817-1135 120 lb. Keg Package

BK 809-1024 400 lb. Keg Package

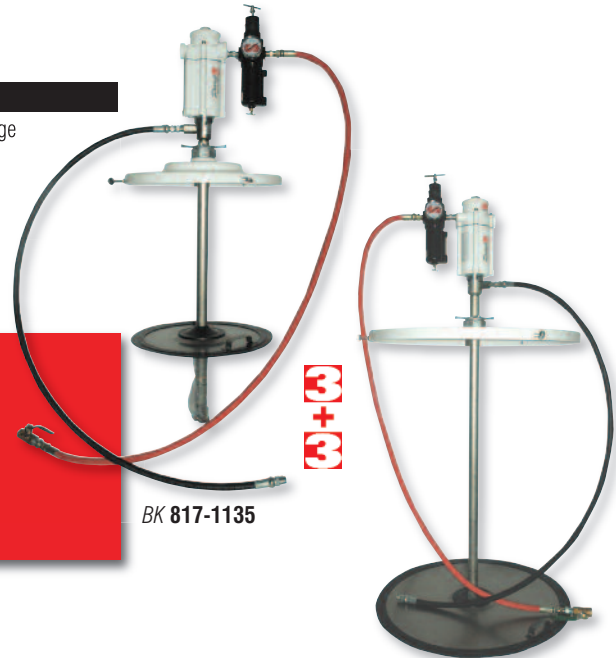

BK 817-1135

BK 809-1024



LOOK FOR THE BEST, LOOK FOR



Long-stroke grease pump specifically for today's high-tech greases. Longer stroke allows for better leading of grease into pump. Outstanding solution for truck shops, off-road equipment shops and agricultural equipment.



ARE YOU INTERESTED IN MAKING A PUMP – REEL PACKAGE?

First choose the Stationary Grease Pump Package from page above that best meets your needs and then order the following:

BK 395-1911 50' x 1/4" Grease Hose Reel

BK 715-1553 Z Swivel – 1/4" NPT(M) x 1/2"-27M

BK 715-1552 Grease Control Handle



BK 395-1911



BK 715-1553



BK 715-1552

BARE GREASE PUMPS & ACCESSORIES



BK 813-5161



BK 395-1917



PM3 55:1 BARE GREASE PUMP

Air inlet: 1/4" NPT (F), grease outlet: 1/4" NPT (F).

BK 813-5161 For 120 Lb. Keg

BK 813-5162 For 400 Lb. Drum

Includes Pump Only.

PM3+3 55:1 HEAVY DUTY BARE GREASE PUMP

Air inlet 3/8" NPT (F), grease outlet; 3/8" NPT (F).

BK 395-1917 For 120 Lb. Keg

BK 395-1919 For 400 Lb. Drum

Includes Pump Only.



BK 825-1004

BK 819-1001



BK 825-1001

CONTAINER COVERS

BK 825-1001 Pail Cover – 35 lb./5 Gallon Pail

BK 825-1004 Pail Cover – 120 lb./16 Gallon Keg

BK 819-1001 Pail Cover – 400 lb./55 Gallon Drum



BK 825-1005

BK 819-1002

BK 825-1002

UNIVERSAL FOLLOWER PLATES

BK 825-1002 Follower Plate – 35 lb./5 Gallon Pail

BK 825-1005 Follower Plate – 120 lb./16 Gallon Keg

BK 819-1002 Follower Plate – 400 lb./55 Gallon Drum



BK 715-1552

HIGH PRESSURE GREASE CONTROL HANDLE

For use with air operated systems. Inlet is 1/4" NPTF with angled rigid outlet pipe with heavy duty 3 jaw hydraulic coupler. 1/8" NPT(F) outlet.

BK 715-1552



BK 715-1553

Z-SWIVELS FOR GREASE PUMPS

For use with grease control handles on air-operated systems. Check hose to properly match Z swivel fitting to hose fitting.

BK 715-1553 Z Swivel – 1/4" NPT(M) x 1/2"-27M

BK 715-1554 Z Swivel – 1/4" NPTM x 1/4" NPTF

35 LB. PAIL PORTABLE ECONOMY GREASE PACKAGE

Includes PM3 55:1 pump with carry handle, 5 ft. air inlet hose, air inlet ball valve, grease control gun with rigid pipe and hydraulic coupler, air filter regulator with gauge and auto drain, 1/4" x 5 ft. high pressure delivery hose, straight swivel, follower plate and container cover.

BK 815-1056*

* PAIL NOT INCLUDED

PORTABLE ECONOMY GREASE PUMP SYSTEM FOR 120 LB. KEG

Includes PM3+3 55:1 grease pump, cover mounting adapter, drum cover, follower plate, 1/4" x 7 ft. high pressure grease hose, high pressure grease control gun with rigid pipe and hydraulic coupler, Z-swivel and four wheel band dolly.

BK 395-1918

PORTABLE PROFESSIONAL GREASE PACKAGE FOR 35 LB. PAIL

Includes PM3 55:1 grease pump with carry handle, air line coupler and nipple, air filter regulator with auto drain, heavy duty pail cover, mounting adapter, follower plate, 7 ft. high pressure grease hose, high pressure grease control gun with rigid pipe and hydraulic coupler and Z-swivel.

BK 817-1132*

* PAIL NOT INCLUDED

PORTABLE GREASE PUMPS

All Balkamp stationary grease pumps from Samson include a combination air regulator with gauge and an air filter with automatic drain.

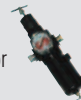

BK 815-1056



BK 395-1918

3
+
3



BK 817-1132



BK 817-1133

PROFESSIONAL PORTABLE GREASE PACKAGE FOR 120 LB. KEG

Includes PM3 55:1 grease pump with air line coupler and nipple, air regulator/filter with auto drain, four wheel band dolly, heavy duty pail cover, follower plate, 1/4" x 7 ft. high pressure delivery hose, Z swivel, grease control gun with rigid pipe and a hydraulic coupler.

BK 817-1133*

* DRUM NOT INCLUDED

PROFESSIONAL HEAVY-DUTY PORTABLE GREASE PUMP SYSTEM FOR 120 LB. KEG

Includes PM3+3 55:1 pump, 2 wheel dolly, 5 ft. air inlet hose, air inlet ball valve, grease control gun with rigid pipe and hydraulic coupler, air filter regulator with gauge and auto drain, 1/4" x 5 ft. high pressure delivery hose, straight swivel, follower plate and container cover.

BK 815-1057*

* DRUM NOT INCLUDED

3
+
3



BK 815-1057

DOLLIES & CARTS FOR GREASE PUMPS



BK 809-5222

TWO-WHEEL DOLLY

For 35 lb. (5 Gal.) or 120 lb. (16 Gal.) drums.
BK 809-5222



BK 825-1000

FOUR-WHEEL BAND DOLLY

For 35 lb. (5 Gal.) pail.
BK 825-1000



BK 395-1904

HEAVY DUTY THREE-WHEEL CART

For 400 lb. (55 Gal.) drum.
BK 395-1904



BK 819-1000

FOUR-WHEEL DELUXE PORTABLE BASE

For 120 lb. (16 Gal.) keg.
BK 819-1000



BK 395-1902

HEAVY DUTY THREE-WHEEL CART

For 400 lb. (55 Gal.) drum with reel mounting bracket.
BK 395-1902



BK 825-1003

BAND-TYPE DOLLY

For 120 lb. (16 Gal.) keg.
BK 825-1003



BK 395-1903

X-FRAME FOUR-WHEEL DOLLY

For 400 lb. (55 Gal.) drum.
BK 395-1903

STATIONARY OIL PUMPS & SUCTION TUBES

STATIONARY OIL PUMPS

All Balkamp stationary grease pumps from Samson include a combination air regulator with gauge and an air filter with automatic drain.



3:1 Samson PM2 pumps are designed for dispensing lubricants approximately 200 ft. to two reels running simultaneously.

5:1 Samson PM4 pumps are designed for dispensing lubricants approximately 400 ft. to four reels running

PM2 3:1 STUB PUMP PACKAGE

Includes PM2 3:1 pump with 2" bung adapter, 5 ft. air hose with 1/4" NPTM on both ends and air filter regulator with auto drain, 5 ft. medium pressure 3/4" hose with 3/4" NPTM ends, air shut-off ball valve.

BK 813-5159

PM4 5:1 STUB PUMP PACKAGE

Includes PM4 5:1 pump with 2" bung adapter, 5 ft. air hose with 1/4" NPTM on both ends and air filter regulator with auto drain, 5 ft. medium pressure 3/4" hose with 3/4" NPTM ends, air shut-off ball valve.

BK 395-1920

WALL MOUNTING INSTALLATION SIPHON KIT

For PM2 (1:1 and 3:1 ratio) or PM4 (5:1 ratio). Includes wall mount bracket, 48" suction tube with foot valve, 2" bung bushing adapter, 8 ft. spring reinforced suction hose with 3/4" F swivel end, 3:1 pump to hose connector 3/4" (M) x 3/4" (F) and 5:1 and 1:1 pump to hose connector 1" (M) x 3/4" (M).

BK 809-1035

PM-2 3:1 BARE STUB PUMP

Includes 2" bung adapter. Fluid inlet: 3/4" NPT (F), outlet: 1" NPT (F). Air inlet: 3/8" NPT (F)

BK 813-5158

PM4 5:1 BARE STUB PUMP

Includes 2" bung adapter. Fluid inlet: 1" NPT (F), outlet: 1" NPT (F). Air inlet: 3/8" NPT (F)

BK 813-5163

PM2 1:1 OIL BARE STUB PUMP

Includes 2" bung bushing adapter. Fluid inlet: 1" NPT(F), outlet: 3/4" NPT (F). Air inlet 1/4" NPT (F).

BK 813-5160

PM2 1:1 SUCTION TUBE

For PM2 1:1 Stub Pump (Fits **BK 813-5160**). Each suction tube comes with packet of Loctite blue thread sealant for use during installation.

- BK 809-1029** 16 Gallon, Keg Length – Pump Length 20 3/4"
- BK 809-1032** 55 Gallon, Drum Length – Pump Length 29 1/2"
- BK 809-1026** 275 Gallon, Tank Length – Pump Length 38 3/4"

PM2 3:1 SUCTION TUBE

For PM2 3:1 stub pump (fits **BK 813-5158** and **BK 813-5159**). Each suction tube comes with packet of Loctite blue thread sealant for use during installation.

- BK 809-1031** 16 Gallon, Keg Length – Pump Length 21 1/4"
- BK 809-1033** 55 Gallon, Drum Length – Pump Length 29 1/2"
- BK 809-1028** 275 Gallon, Tank Length – Pump Length 39"

PM4 5:1 SUCTION TUBE

For PM4 5:1 stub pump (fits **BK 813-5163** and **BK 395-1920**). Each suction tube comes with packet of Loctite blue thread sealant for use during installation.

- BK 809-1030** 16 Gallon, Keg Length – Pump Length 19 3/4"
- BK 809-1034** 55 Gallon, Drum Length – Pump Length 27 3/4"
- BK 809-1027** 275 Gallon Tank Length – Pump Length 37 1/4"

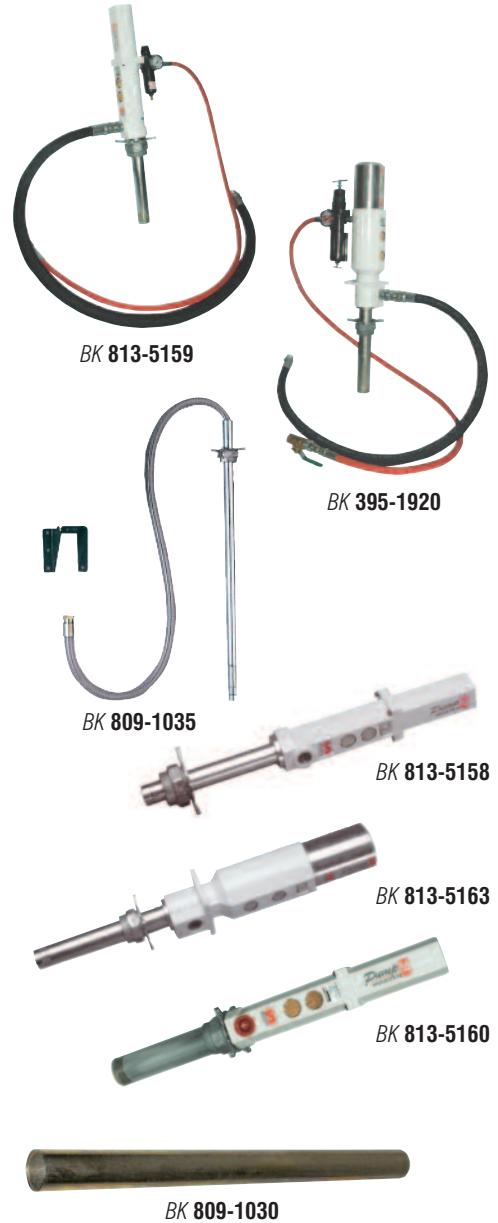

ARE YOU INTERESTED IN MAKING A PUMP – REEL PACKAGE?

1. First choose the Oil Pump Package and suction tube that best meets your needs and then order the following:
2. Select hose reel – 50' x 1/2" Oil Hose Reel (**See page 8**)
3. Choose desired control handle (**See page 9**)



BK 395-1916

BULK FLUID DISPENSING PACKAGES

Many auto and heavy duty fleet repair locations are buying their lubricants in bulk to help lower costs. The new Cubet System from Samson gives you everything you need to be in the bulk lubricant business in one package.

BULK FLUID DISPENSING PACKAGE

Bulk fluid dispensing package includes 230 gallon (880 liter) CUBET, 3:1 ratio air-operated fluid pump with reel, connecting hose, quick air coupler and nipple, 1/2" x 30' MP hose reel with mounting plate, electronic-metered control handle with holder, and a cage and platform base with 4" legs. It can easily be moved by a forklift. Shipped completely assembled.

BK 395-1916

1:1 DIAPHRAGM PUMP PACKAGE -1"

Includes 1" aluminum diaphragm pump with 1" inlet and outlet. General purpose pump designed for use with heavier fluids at faster flow rates. Includes filter regulator with auto drain, 5' x 3/8" air inlet hose, 5' x 1" dia. suction hose 5' x 1" dia. discharge hose.

BK 395-1900



BK 395-1900

1:1 DIAPHRAGM PUMP PACKAGE - 1/2"

Includes 1/2" poly diaphragm pump with 1/2" inlet and outlet. General purpose pump designed for system use with water based fluids and general lubricants. Includes filter regulator with auto drain, 5' x 1/4" air inlet hose, 5' x 1/2" diameter suction hose and 5' x 1/2" discharge hose.

BK 395-1921

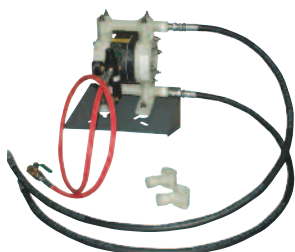

BK 395-1921

AIR-OPERATED PORTABLE PUMP SYSTEM FOR GEAR LUBE

Air operated portable pump system for gear lube for use in 16 gallon open top keg. Includes PM2 3:1 air pump, keg cover, dolly, air regulator/filter with bleed type auto drain, 7' fluid delivery hose, and digital metered control handle.

BK 809-1025



BK 809-1025

AIR-OPERATED PORTABLE PUMP SYSTEM FOR OIL & AUTOMATIC TRANSMISSION FLUID

For use in 16 gallon open top keg. Includes PM2 3:1 air pump, keg cover, dolly, air regulator/ filter with bleed type auto drain, 7' fluid delivery hose, and digital metered control handle.

BK 395-1913



BK 395-1913

HAND OPERATED PUMP PACKAGES

HAND-OPERATED NON-METERED GEAR LUBE SYSTEM

Non-Metered – 2:1 ratio hand operated non-metered gear lube system for use in open top 16 gallon keg. Includes hand pump, keg cover, 5' hose, spout, and band dolly.

BK 817-1130*

* DRUM NOT INCLUDED



BK 817-1130

BK 817-1131

HAND-OPERATED METERED GEAR LUBE SYSTEM

Metered – 2:1 ratio hand operated metered gear lube system for use in open top 16 gallon keg. Includes hand pump, meter, keg cover, 5' hose, spout, and band dolly.

BK 817-1131*

* DRUM NOT INCLUDED

HAND-OPERATED GREASE PUMP PACKAGE 35 LB. PAIL

Heavy duty hand operated high pressure (5,000 PSI) grease pump unit. Fits 35 lb. pail and includes pump, cover, 5 ft. hose, suction pipe with coupler, carry handle and follower plate.

BK 815-1051



BK 815-1051

HEAVY-DUTY HAND-OPERATED GREASE PUMP PACKAGE

High pressure (6,000 PSI) self contained lever action grease pump. Oval shaped 4 1/2 gallon steel container with foot rest. Includes 7 ft. grease hose and hydraulic coupler. Adjustable pressure and volume.

BK 813-5164



BK 813-5164

HAND-OPERATED BEARING PACKER

Heavy duty hand operated bearing packer fits 35 lb. pail or 120 lb. keg. Includes pump, cover, bearing packer, dust cap and follower plate.

BK 395-1912 For 35 Lb. Pail

BK 823-1324 For 120 Lb. Keg



BK 395-1912

2:1 SPIGOT PUMP FOR 55 GALLON DRUM

2:1 long stroke pump (4") allows for one pump for all fluids, including gear lube. Curved outlet pipe and non-drip spring loaded spigot valve. Built in shelf holds container and catches spills that drain back through filtered bushing into drum.

BK 395-1915



BK 395-1915

HOSE REELS

All Samson hose reels include a 2' long inlet hose for easily connecting reel to piping.

- Powder-coated Finish for Durability and Professional Appearance
- All Feature a Double Pedestal Arm
- Permanently Lubricated Bearings Means Consistent Performance
- Heavy Duty Latch Mechanism and Hardened Shaft
- Full Flow Porting



BK 395-1906



BK 395-1907



BK 395-1908



BK 395-1910



BK 395-1909



BK 395-1911



BK 715-1558



BK 823-1323

50' X 3/8" HEAVY-DUTY DOUBLE PEDESTAL ARM AIR HOSE REEL

With 1/2" x 2' inlet hose.
BK 395-1906

50' X 3/8" HEAVY-DUTY DOUBLE PEDESTAL ARM NITROGEN HOSE REEL

With 1/2" x 2' inlet hose.
BK 395-1907

50' X 1/2" HEAVY-DUTY DOUBLE PEDESTAL ARM AIR HOSE REEL

With 1/2" x 2' inlet hose.
BK 395-1908

50' X 1/2" HEAVY-DUTY DOUBLE PEDESTAL ARM OILS/ATF HOSE REEL

With 1/2" x 2' inlet hose.
BK 395-1910

50' X 1/2" HEAVY-DUTY DOUBLE PEDESTAL ARM NITROGEN HOSE REEL

With 1/2" x 2' inlet hose.
BK 395-1909

50' X 1/4" HEAVY-DUTY DOUBLE PEDESTAL ARM GREASE HOSE REEL

With 1/2"-27 F fitting and 1/2" x 2' inlet hose.
BK 395-1911

UNIVERSAL HOSE STOPS

- BK 715-1556 Hose stop for 1/4" hose
- BK 715-1557 Hose stop for 3/8" hose
- BK 715-1558 Hose stop for 1/2" hose

50' X 3/8" ECONOMY AIR HOSE REEL

With 1/2" x 2' inlet hose.
BK 823-1323

Part No.	Uses	Hose Length	Hose Inside Diameter	Hose End Fitting	Working Pressure (PSI)
BK 823-1323	Air/Water/Water Based Fluids	50 Ft.	3/8"	3/8" NPT (M)	300
BK 395-1906	Air/Water/Water Based Fluids	50 Ft.	3/8"	3/8" NPT (M)	300
BK 395-1907	Nitrogen	50 Ft.	3/8"	3/8" NPT (M)	300
BK 395-1908	Air/Water/Water Based Fluids	50 Ft.	1/2"	1/2" NPT (M)	300
BK 395-1909	Nitrogen	50 Ft.	1/2"	1/2" NPT (M)	300
BK 395-1910	Oils, ATF	50 Ft.	1/2"	1/2" NPT (M)	1500
BK 395-1911	Grease	50 Ft.	1/4"	1/2"-27 (F) Fine Thread	5000

ELECTRONIC PRESET METERED HANDLE

Designed to meter and dispense bulk fluids – Motor Oils (SAE 5-50), Gear Oils (SAE 80-240), ATF, Anti-freeze and Hydraulic Fluid. Includes a straight pipe with semi-automatic drip tip – ½" NPT(M) and a ½"(F) inlet swivel. Programmable to dispense quarts, pints, liters and gallons. Includes ¾" M x ½" F heavy duty ball bearing swivel. Uses four AA batteries.

BK 825-5039



BK 825-5039

DIGITAL METERED CONTROL HANDLE WITH FLEXIBLE SPOUT

Includes meter, ball-bearing swivel inlet and flexible multi-fluid spout. Can be programmed to dispense quarts, pints, liters and gallons and has a resettable totalizer. Includes ¾" M x ½" F heavy duty ball bearing swivel. Uses two AAA batteries.

BK 825-5038



BK 825-5038

DIGITAL METERED CONTROL HANDLE WITH RIGID SPOUT

Includes meter, ball-bearing swivel inlet and rigid multi-fluid spout. Can be programmed to dispense quarts, pints, liters and gallons and has a resettable totalizer. Includes ¾" M x ½" F heavy duty ball bearing swivel. Uses two AAA batteries.

BK 395-1914



BK 395-1914

ODOMETER MECHANICAL METERED CONTROL HANDLE

Includes flexible multi-fluid spout with manual tip. Meters in quarts and totalizes in gallons.

BK 825-5037



BK 825-5037

NON-METERED CONTROL HANDLE WITH RIGID OUTLET

Includes ¾" M x ½" F heavy duty ball bearing swivel. 1500 PSI and 8 GPM flow rate.

BK 827-1245



BK 827-1245

NON-METERED HIGH FLOW CONTROL HANDLE WITH HIGH FLOW RIGID OUTLET

Angled Rigid Outlet. 1500 PSI and 16 GPM flow rate.

BK 395-1901



BK 395-1901

NON-METERED CONTROL HANDLE WITH FLEXIBLE OUTLET

Includes ¾" M x ½" F heavy duty ball bearing swivel. 1500 PSI and 8 GPM flow rate.

BK 827-1246



BK 827-1246

UNIVERSAL SEMI-AUTOMATIC DRIP TIP

¼" NPT(F) – Auto Open, Manual Close

BK 715-1555



BK 715-1555

USED FLUID HANDLING

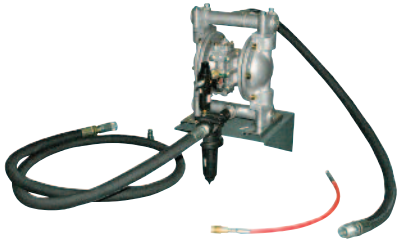

BK 823-1325

USED OIL EVACUATION SYSTEM

Includes 1" diaphragm pump, 10' suction hose, 5' fluid discharge hose, 2' air inlet hose, air filter regulator with auto drain, dry break couplings, and wall mount bracket.

BK 823-1325



BK 395-1905

LOW PROFILE MOTORCYCLE OIL DRAIN

Special low profile with swing arm funnel tray allows easy positioning for hard to access drain plugs. Ideal for motorcycles, marine, off-road and farm applications. Holds 10 gallons – air discharge to empty unit when full. Drain tray adjusts from 29" to 37" high.

BK 395-1905



BK 811-1240

PORTABLE USED FLUID DRAIN WITH DRUM

Includes 16 gallon keg with evacuation fitting, 17" diameter, 5 gallon steel bowl, telescoping draintube (45"-71"), dipstick and 16 gallon drum and drum cover. Also includes band dolly and evacuation fitting.

BK 811-1240



BK 823-1326

PORTABLE USED FLUID DRAIN WITHOUT DRUM

17" diameter steel drain bowl. Bowl has a 5 gallon capacity and comes with telescoping drain tube, dolly for 16 gallon drum, dipstick and cover for 16 gallon drum.

BK 823-1326*

* Drum is not included.



BK 809-5223

5 GALLON STEEL OIL DRAIN

12" diameter steel bowl with telescoping tube (41" – 70") with 5 gallon capacity receiver.

BK 809-5223



BK 819-1003

HIGH LEVEL SHUT-OFF FOR USED FLUID TANKS

Controls air supply to evacuation pump. When tank level reaches 7/8's full, float shuts off air supply to evacuation pump. Includes non-electric float level sensor alarm with automatic overfill shut-off valve and alarm whistle. 360 degree rotating mounting collar allows indexing to fit virtually all single wall tanks.

BK 819-1003

SYSTEM DESIGN QUESTIONS

Copy this page, fill it out completely, attach a sketch of how you want the system to look/operate and fax to Samson at (800) 699-2693.

WHAT TYPE PRODUCTS ARE BEING STORED? THIS INFORMATION MUST BE FILLED OUT FOR EACH PRODUCT.

IN WHAT TYPE CONTAINER IS EACH PRODUCT BEING STORED?

- Include tank Gallonage and dimensions if product is being stored in a tank
- Specify pail (5 gallons), keg (16 gallons) , or drum (55 gallons); be certain to specify if container is open top or bung mount
- Other; describe

DOES CUSTOMER HAVE A PREFERENCE FOR PUMP MOUNTING?

- Tank mount (if tank used for storage)
- Wall mount
- Container mount

HOW MANY DISPENSE POINTS FOR EACH PRODUCT

- Hose reels and desired length
- Oil bar and desired number of different product per oil bar
- Other; describe

WHAT TYPE CONTROL HANDLE FOR EACH DISPENSE POINT?

- Preset digital
- Metered digital
- Preset mechanical
- Metered mechanical
- Non-metered standard flow (approximately 5 GPM)
- Non-metered high flow (approximately 10 GPM)

MAKE A SKETCH OF SHOP LAYOUT AND INSTALLATION; AT A MINIMUM, INCLUDE;

- Tank room location plus any other locations where product is stored and pumped
- Dispense point locations
- Part room location
- All horizontal distances between tank room, dispense points, parts room, and any other site specific information
- All vertical distances from floor at product storage location to the highest point of tubing or dispense point location

>> See next page for typical installation layout.

TYPICAL INSTALLATION LAYOUT

SERVICE FACILITY

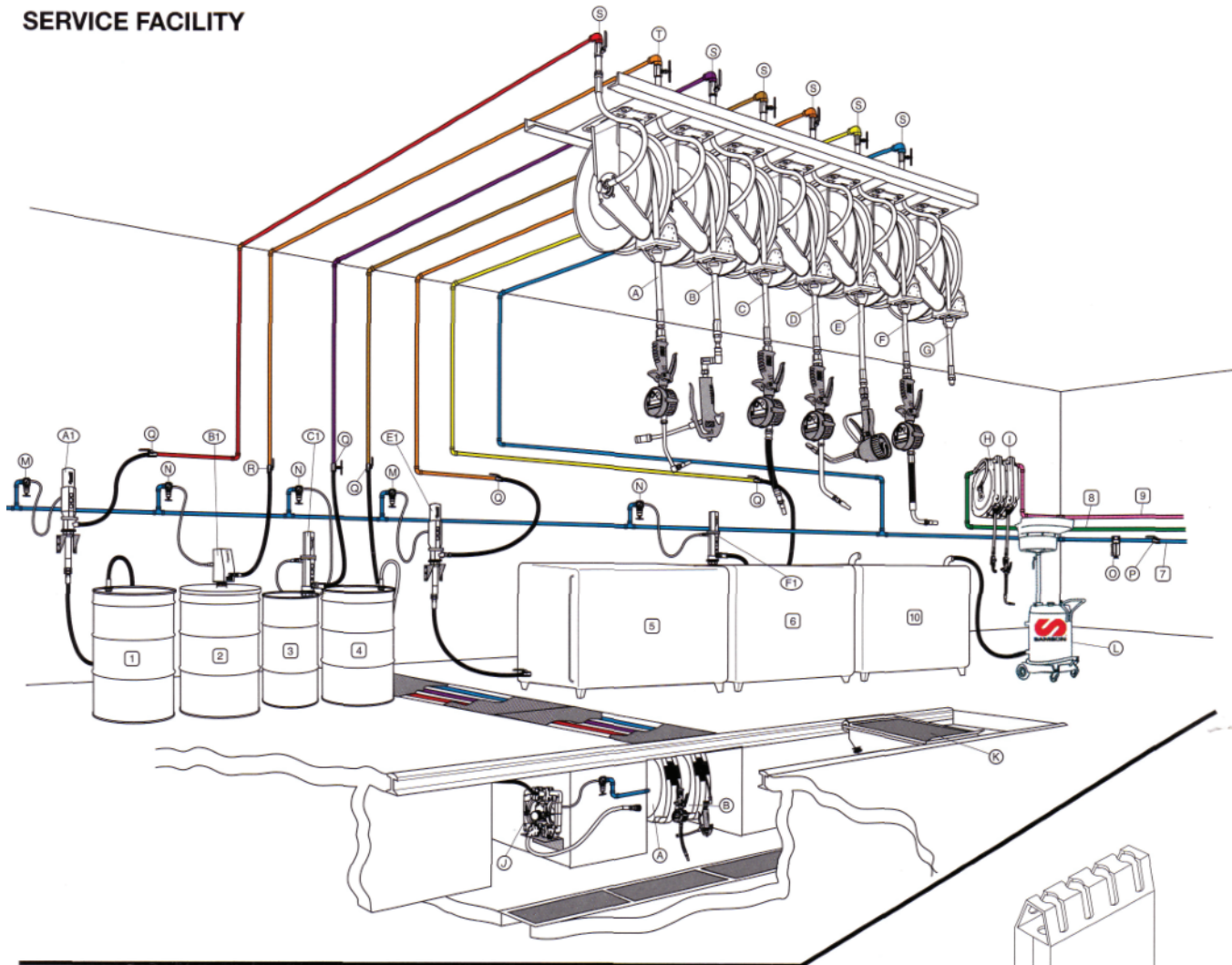

FAST LUBE

*"Make A Bay Pay
The Samson Way"*

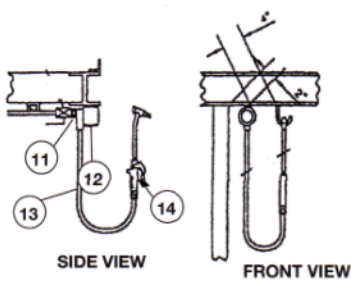
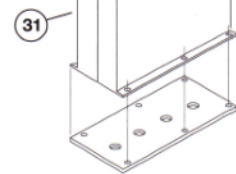

GEAR LUBE

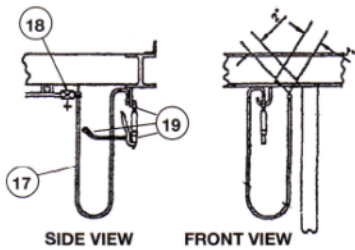

CHASSIS GREASE

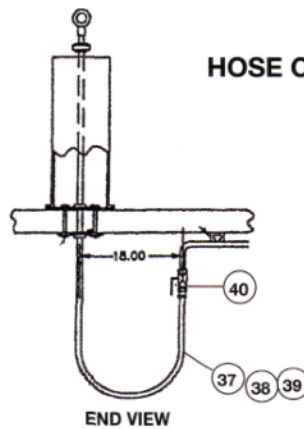

END VIEW

HOSE CONSOLE

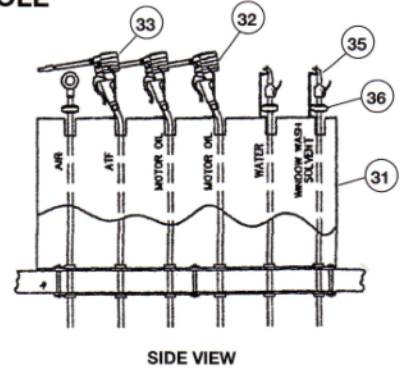

SIDE VIEW

TYPICAL INSTALLATION LAYOUT

Item No.	Description
1 GEAR OIL	
A	Open hose reel kit with electronic metered handle.
A	(Pit) Open hose reel kit with non-metered handle.
AI	Wall mounted pump kit-5:1/HD ratio.
M	Pressure regulator 1/2".
Q	Shut off valve. 3/4" FF.
S	Shut off valve. 1/2" FF.
2 GREASE	
B	Open hose reel kit with grease control handle.
BI	Air operated pump kit, 55:1 for 400 lb. drums.
N	Pressure regulator 1/4".
R	High pressure grease valve 1/2".
T	High pressure grease valve 1/2".
3 (A.T.F.)	
C	Open hose reel kit with electronic metered handle.
CI	Drum mounted pump kit - 3:1 ratio.
N	Pressure regulator 1/4".
Q	Shut off valve 3/4" FF.
S	Shut off valve. 1/2" FF.
4/5 MOTOR OIL	
D	Open hose reel kit with electronic metered handle.
E	Open hose reel kit with preset control handle.
EI	Wall mounted pump kit for tanks w/lower outlet - 5:1/HD ratio.
M	Pressure regulator 1/2".
N	Pressure regulator 1/4".
Q	Shut off valve 3/4" FF.
S	Shut off valve 1/2" FF.
6 HYDRAULIC OIL	
F	Open hose reel kit with electronic metered handle.
FI	Tank mounted pump kit - 3:1 ratio.
N	Pressure regulator 1/4".
Q	Shut off valve 3/4" FF.
S	Shut off valve 1/2" FF.
7 AIR FILTER	
G	Open hose reel kit with quick air coupling.
Option	Standard tire inflator.
O	Air filter 1/2".
P	Shut off valve 1/2" FF.
8 WATER	
H	Individually enclosed hose reel kit with bibb.
-	Shut off valve 1/2" FF.
9 ANTIFREEZE	
I	Individually enclosed hose reel kit with control handle.
-	Stainless steel air operated pump for systems 1:1/SS ratio.
-	Pressure regulator 1/4".
-	Shut off valve 1/2" FF.
10 USED OIL	
J	Diaphragm discharge pump kit.
K	Used oil rolling drainer for pits.
L	Portable used oil drainer - air discharge.

Item No.	Description
11	Shut off valve 3/4" FF (MP)
12	Pint inline meter
13	1/2" x 15' M.E Fluid Hose
14	Gear Lube Control Handle

Item No.	Description
17	1/4" x 15' H.E Grease Hose
18	High Pressure Grease Valve 1/2"
19	Grease Control Handle

Item No.	Description
31	6 Hose Dispensing Console
32	Electric Meter Oil Control Handle
33	Electric Meter ATF Control Handle
35	Water/WWS Bibb
36	Hose Stop
37	1/2" x 15' M.P Fluid Hose
38	1/2" x 15' L.P. Water Hose
39	1/2" x 15' L.P. Air Hose
40	Shut Off Valve 1/2" FF (LP)

